



FORM 4 (4th Year) GRAPHICAL COMMUNICATION MARKING SCHEME

Question No.1 (a) **Safe Condition Sign**

shading neatly and uniformly the appropriate areas	2	
using the green colour in accordance with approved standards	2	
Total marks for question No. 1(a)		4

Question No.1 (b) **Enlarging Push-Button**

drawing radials from point P	1	
locating the centre line of the top arc	1	
drawing the top arc	1	
drawing the chord that joins the two edges of the top arc	1	
determining the width of the shaft and drawing two vertical lines	1	
drawing the lower contact base	2	
neatness / presentation	1	
Total marks for question No. 1(b)		8

Total marks for question No. 1(a) and (b)		12
--	--	-----------

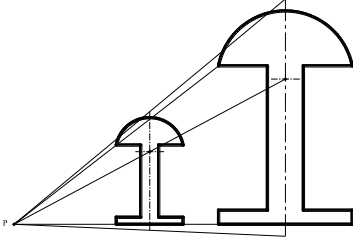
 <p>Question 1 (a)</p>	 <p>Question 1 (b)</p>
---	--

Question No. 2 (a) **Conversion of Area**

dropping the vertical line from the apex to the base	1	
bisecting the vertical height of the triangle	1	
drawing line parallel to base and passing through the bisected line	1	
completing the rectangle equal in area to the triangle	1	
drawing a quadrant having the rectangle's height as its radius and the right-hand bottom corner of the rectangle as its centre	1	
bisecting half the perimeter of the rectangle	1	
drawing semi-circle to find the height of the required square (60mm)	1	
spacing / neatness / presentation	1	
Total marks for question No. 2 (a)		8

Question No. 2(b)

Calculation of Area

using the counting squares or the mid-ordinate method to calculate graphically the shaded area of the rectangle	4	
stating the area to be printed $20 \text{ cm}^2 \pm 0.5 \text{ cm}^2$	1	
neatness and presentation	1	
Total marks for question No. 2 (b)		6

Total marks for question No. 2 (a) and (b)		14
---	--	-----------

Question 2 (a)

Question 2 (b)

Question No. 3

Sectional View

projecting and drawing the two horizontal holes	2	
projecting and drawing the two open ended slotted holes	2	
drawing the web	2	
drawing section lines where appropriate (deduce 2 marks if the web is shown sectioned)	4	
drawing the projection symbol	2	
presentation / neatness	2	
Total marks for question No. 3		14

A-A

Projection Symbol

Question 3

Question No. 4

Hyperbola

dividing plan into a number of equal sectors	1	
projecting generators from the plan to the front view	2	
projecting generators from the plan to the end view	2	
projecting lines from intersections between the generators and the cutting plane from the end view to the front view	2	
marking the proper points of intersections in the front view	1	
lining in with smooth curves	4	
naming the curve - Hyperbola	1	
neatness and presentation	1	
Total marks for question No. 4		14

Question 4

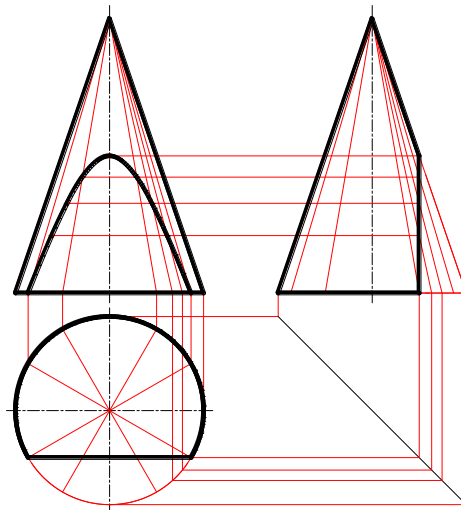

Question No. 5

Helix

dividing plan into a number of equal sectors	1	
projecting generators from the plan to the front view	1	
projecting the divisions from the given development to the front view	2	
marking the correct points of intersection	2	
drawing a smooth helical curve	4	
lining in the straight line PR	1	
indicating the hidden part of the curve by drawing hidden lines	1	
presentation / neatness	2	
Total marks for question No. 6		14

Question 5

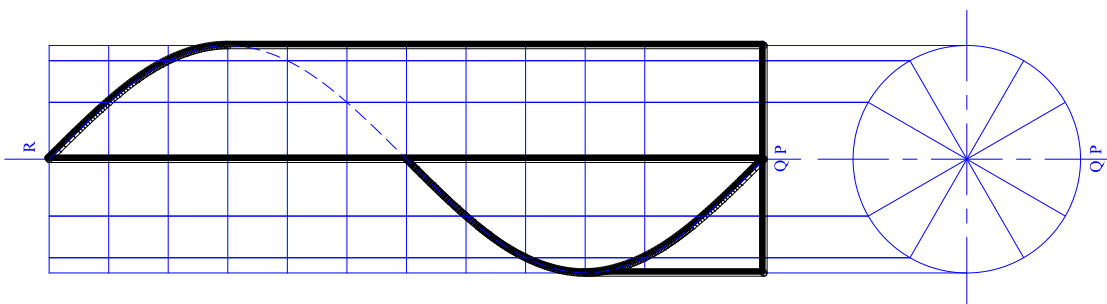

Question No. 6

Development

completing the plan	3	
finding the true length of the sloping edge of the pyramid	1	
drawing the radial development using the correct true lengths	4	
drawing the true shape of the opening in the development	2	
using the proper line types i.e. construction, folding and outline	3	
neatness and presentation	1	
Total marks for question No. 6		14

Question No. 7

Freehand Sketch / Planometric

a) Freehand Sketch: drawing a well-proportioned freehand sketch	6	
b) Rendering: shading the drawing to give a shiny metal finish	2	
c) Planometric Projection:		
drawing the planometric crate	1	
locating the centre lines of the circular parts	1	
drawing the top inner circle	1	
drawing the top outer circle	1	
drawing the lower circles	2	
drawing the rectangular portion of the fork	2	
neatness and presentation	2	
Total marks for question No. 7		18

